

Projeto 14

Prof. D M Soares

Controle de um motor DC usando uma chave quadrupolo L293

```
// Project 16 - Using an L293D Motor Driver IC
#define switchPin 2 // switch input
#define motorPin1 3 // L293D Input 1
#define motorPin2 4 // L293D Input 2
#define speedPin 9 // L293D enable Pin 1
#define potPin 0 // Potentiometer on Analog Pin 0
int Mspeed = 0; // a variable to hold the current speed value
void setup() {
    //set switch pin as INPUT
    pinMode(switchPin, INPUT);
    // set remaining pins as outputs
    pinMode(motorPin1, OUTPUT);
    pinMode(motorPin2, OUTPUT);
    pinMode(speedPin, OUTPUT);
}
void loop() {
    Mspeed = analogRead(potPin)/4; // read the speed value from the potentiometer
    analogWrite(speedPin, Mspeed); // write speed to Enable 1 pin
    if (digitalRead(switchPin)) { // If the switch is HIGH, rotate motor clockwise
        digitalWrite(motorPin1, LOW); // set Input 1 of the L293D low
        digitalWrite(motorPin2, HIGH); // set Input 2 of the L293D high
    }
    else { // if the switch is LOW, rotate motor anti-clockwise
        digitalWrite(motorPin1, HIGH); // set Input 1 of the L293D low
        digitalWrite(motorPin2, LOW); // set Input 2 of the L293D high
    }
}
}
```

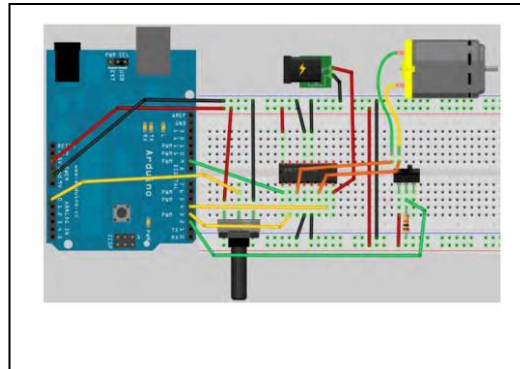

Chave quadrupolo:

Olhando a figura à direita temos um motor DC acionado pela fonte V_{in} através da chave quadrupolo. Fechando (S1 , S4) e abrindo (S2 , S3) a corrente passa pelo motor M da esquerda para a direita. O motor girará em um sentido. Fechando (S2, S3) e abrindo (S1,S4) o motor gira em sentido contrário.

Estas chaves podem ser implementadas com relés, transistores, etc. Existem CIs que fazem esta função.

Um CI conhecido é o L293.

Nas paginas que seguem mostramos partes do manual dessa chave. Essas informações bastam para a implementação do controle do motor DC.

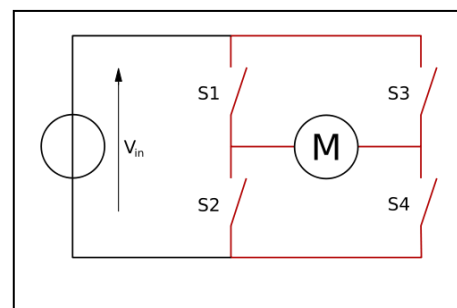

L293, L293D QUADRUPLE HALF-H DRIVERS

SLR9008B - SEPTEMBER 1986 - REVISED JUNE 2002

- Featuring Unitorde L293 and L293D Products Now From Texas Instruments
- Wide Supply-Voltage Range: 4.5 V to 36 V
- Separate Input-Logic Supply
- Internal ESD Protection
- Thermal Shutdown
- High-Noise-Immunity Inputs
- Functional Replacements for SGS L293 and SGS L293D
- Output Current 1 A Per Channel (600 mA for L293D)
- Peak Output Current 2 A Per Channel (1.2 A for L293D)
- Output Clamp Diodes for Inductive Transient Suppression (L293D)

description

The L293 and L293D are quadruple high-current half-H drivers. The L293 is designed to provide bidirectional drive currents of up to 1 A at voltages from 4.5 V to 36 V. The L293D is designed to provide bidirectional drive currents of up to 600-mA at voltages from 4.5 V to 36 V. Both devices are designed to drive inductive loads such as relays, solenoids, dc and bipolar stepping motors, as well as other high-current/high-voltage loads in positive-supply applications.

All inputs are TTL compatible. Each output is a complete totem-pole drive circuit, with a Darlington transistor sink and a pseudo-Darlington source. Drivers are enabled in pairs, with drivers 1 and 2 enabled by 1,2EN and drivers 3 and 4 enabled by 3,4EN. When an enable input is high, the associated drivers are enabled and their outputs are active and in phase with their inputs. When the enable input is low, those drivers are disabled and their outputs are off and in the high-impedance state. With the proper data inputs, each pair of drivers forms a full-H (or bridge) reversible drive suitable for solenoid or motor applications.

On the L293, external high-speed output clamp diodes should be used for inductive transient suppression.

A V_{CC1} terminal, separate from V_{CC2} , is provided for the logic inputs to minimize device power dissipation.

The L293 and L293D are characterized for operation from 0°C to 70°C.

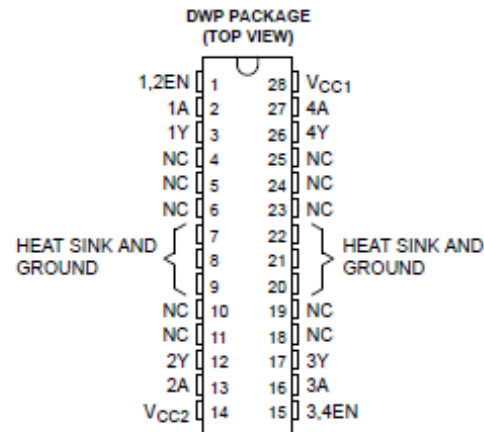
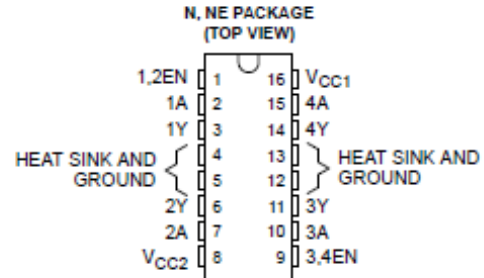

L293, L293D QUADRUPLE HALF-H DRIVERS

SLR0088B - SEPTEMBER 1986 - REVISED JUNE 2002

block diagram

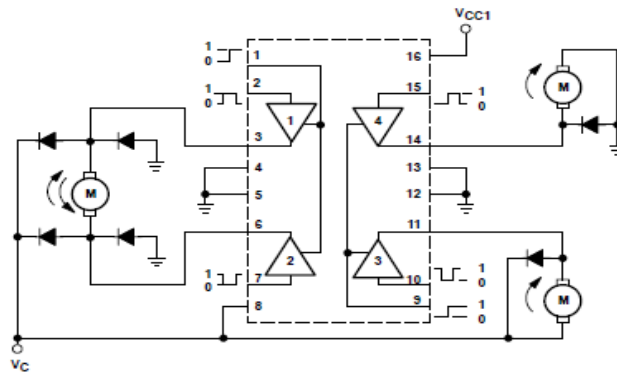

NOTE: Output diodes are internal in L293D.

TEXAS INSTRUMENTS AVAILABLE OPTIONS

T _A	PACKAGE
	PLASTIC DIP (NE)
0°C to 70°C	L293NE L293DNE

Unitrode Products from Texas Instruments AVAILABLE OPTIONS

T _A	PACKAGED DEVICES	
	SMALL OUTLINE (DWP)	PLASTIC DIP (N)
0°C to 70°C	L293DWP L293DDWP	L293N L293DN

The DWP package is available taped and reeled. Add the suffix TR to device type (e.g., L293DWPTR).

L293, L293D QUADRUPLE HALF-H DRIVERS

SLR0088B - SEPTEMBER 1986 - REVISED JUNE 2002

schematics of inputs and outputs (L293D)

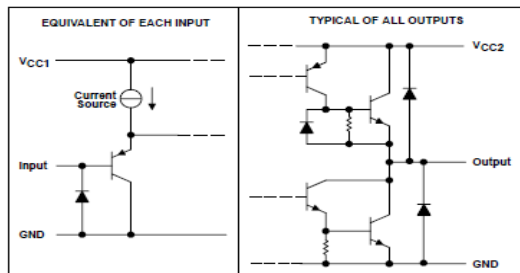

absolute maximum ratings over operating free-air temperature range (unless otherwise noted)†

Supply voltage, V _{CC1} (see Note 1)	36 V
Output supply voltage, V _{CC2}	36 V
Input voltage, V _I	7 V
Output voltage range, V _O	-3 V to V _{CC2} + 3 V
Peak output current, I _O (nonrepetitive, t ≤ 5 ms): L293	±2 A
Peak output current, I _O (nonrepetitive, t ≤ 100 μs): L293D	±1.2 A
Continuous output current, I _O : L293	±1 A
Continuous output current, I _O : L293D	±600 mA
Continuous total dissipation at (or below) 25°C free-air temperature (see Notes 2 and 3)	2075 mW
Continuous total dissipation at 80°C case temperature (see Note 3)	5000 mW
Maximum junction temperature, T _J	150°C
Lead temperature 1.6 mm (1/16 inch) from case for 10 seconds	260°C
Storage temperature range, T _{stg}	-65°C to 150°C

† Stresses beyond those listed under "absolute maximum ratings" may cause permanent damage to the device. These are stress ratings only, and functional operation of the device at these or any other conditions beyond those indicated under "recommended operating conditions" is not implied. Exposure to absolute-maximum-rated conditions for extended periods may affect device reliability.

- NOTES: 1. All voltage values are with respect to the network ground terminal.
 2. For operation above 25°C free-air temperature, derate linearly at the rate of 16.6 mW/°C.
 3. For operation above 25°C case temperature, derate linearly at the rate of 71.4 mW/°C. Due to variations in individual device electrical characteristics and thermal resistance, the built-in thermal overload protection may be activated at power levels slightly above or below the rated dissipation.

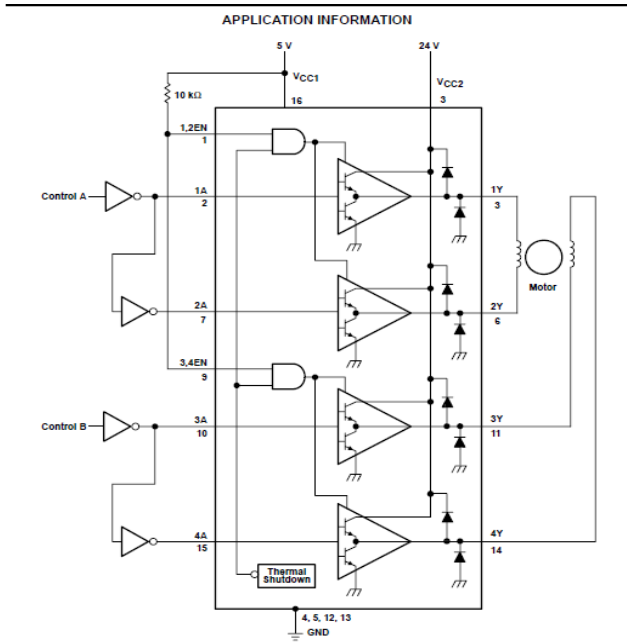

Figure 3. Two-Phase Motor Driver (L293D)

Fim