

Timer 555. Monostable, PWM

Prof. David M Soares

F540

Multivibradores Monoestáveis

- ✓ Apresenta somente um estado estável;
- ✓ Estimulo de gatilho é necessário para o estado instável;
- ✓ O estado instável permanece por um período determinado.

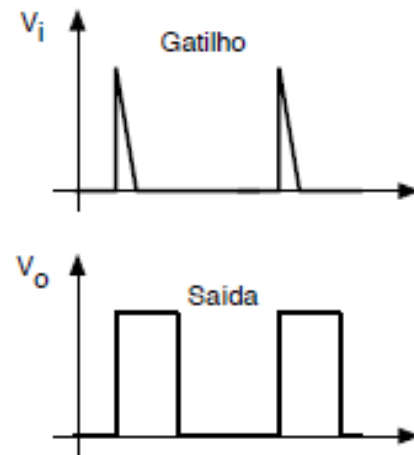
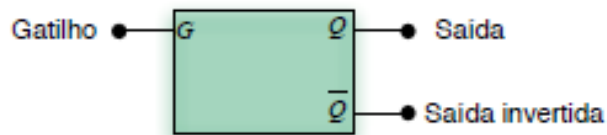

Multivibradores Biestáveis

- ✓ Apresenta dois estados estáveis;
- ✓ Estimulo de gatilho é necessário para o a troca de estados;
- ✓ A troca dos estado ocorre pelo disparo do gatilho.

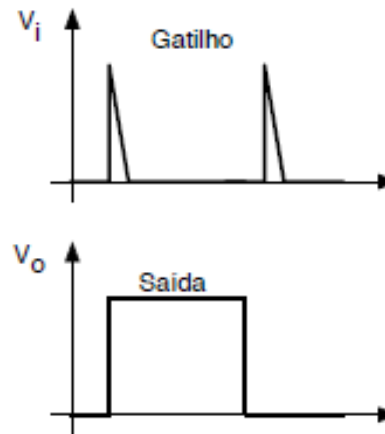
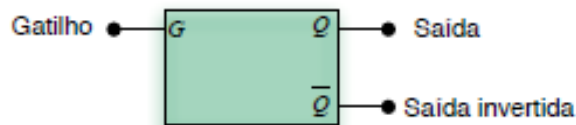

Basic NAND Gate

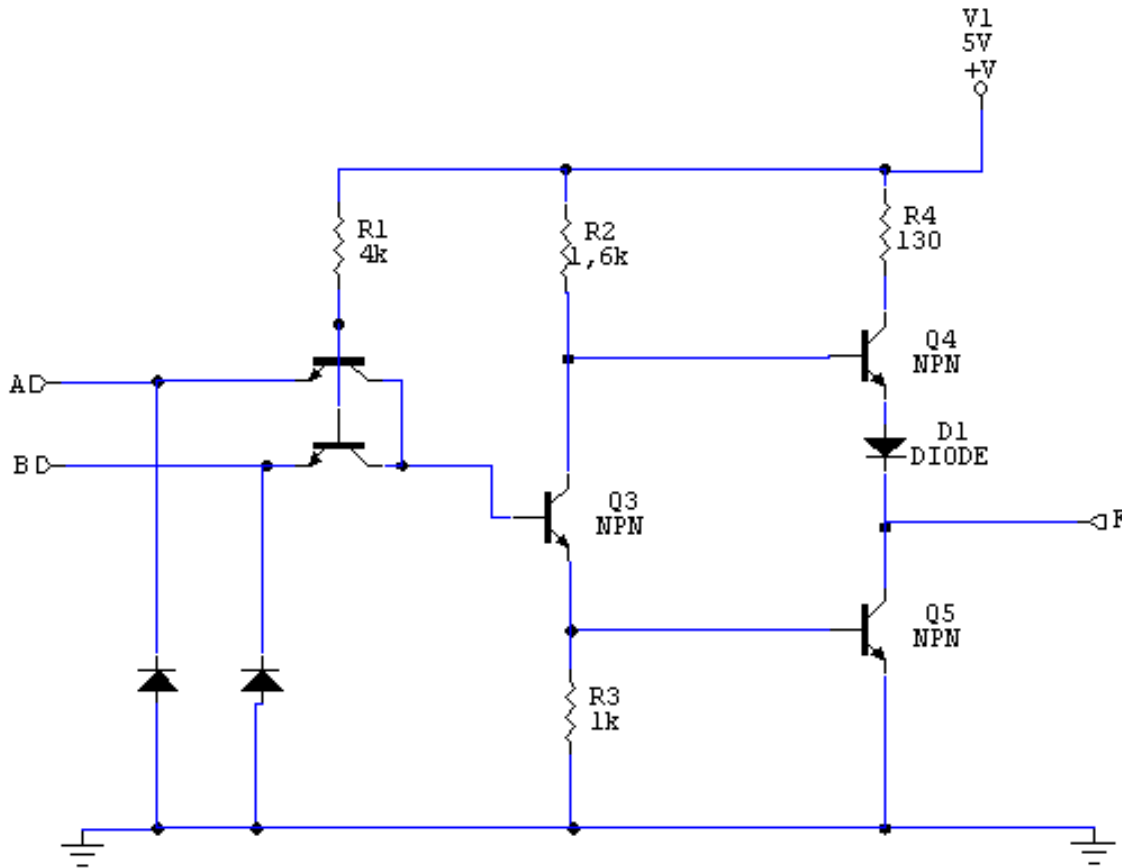

A/V	B/V	F/V
0	0	5
0	5	5
5	0	5
5	5	0

Multivibradores Astáveis

- ✓ Não apresenta estado estável;
- ✓ Não existe a necessidade de disparo de gatilho;
- ✓ Os estados variam constantemente, gerando um sinal oscilante na saída.

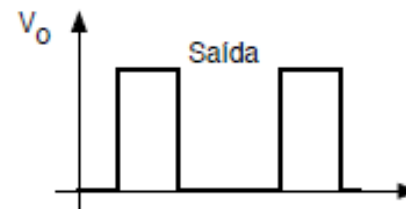
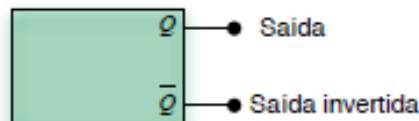

Nand gate (2 inputs)

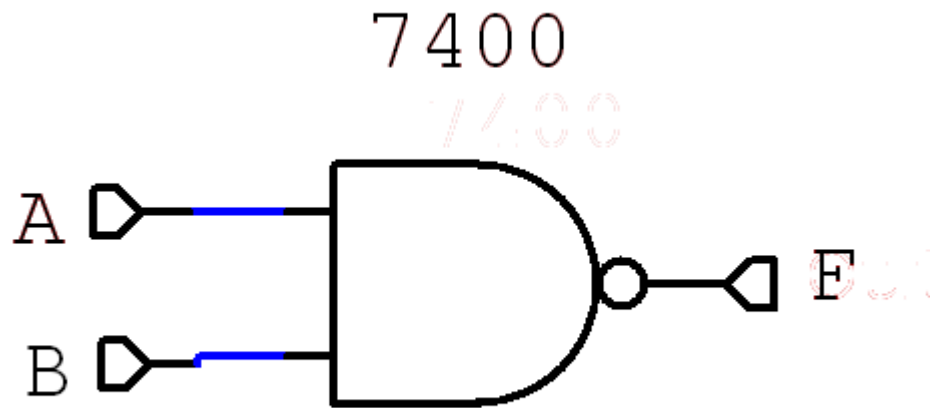

A	B	F
0	0	1
0	1	1
1	0	1
1	1	0

Flip Flop SR

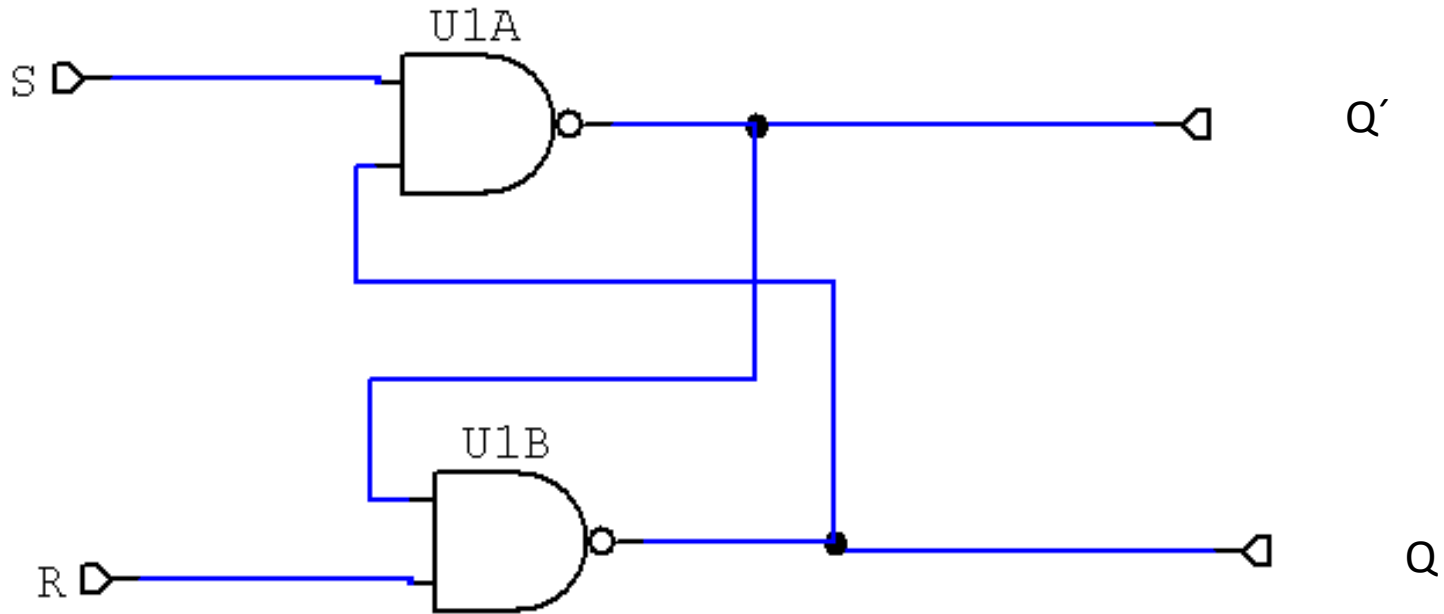

R	S	Q	Q'
1	1	Q	Q'
0	1	1	0
1	0	0	1
0	0	1	1

Circuito Integrado 555

Diagrama em blocos do CI 555

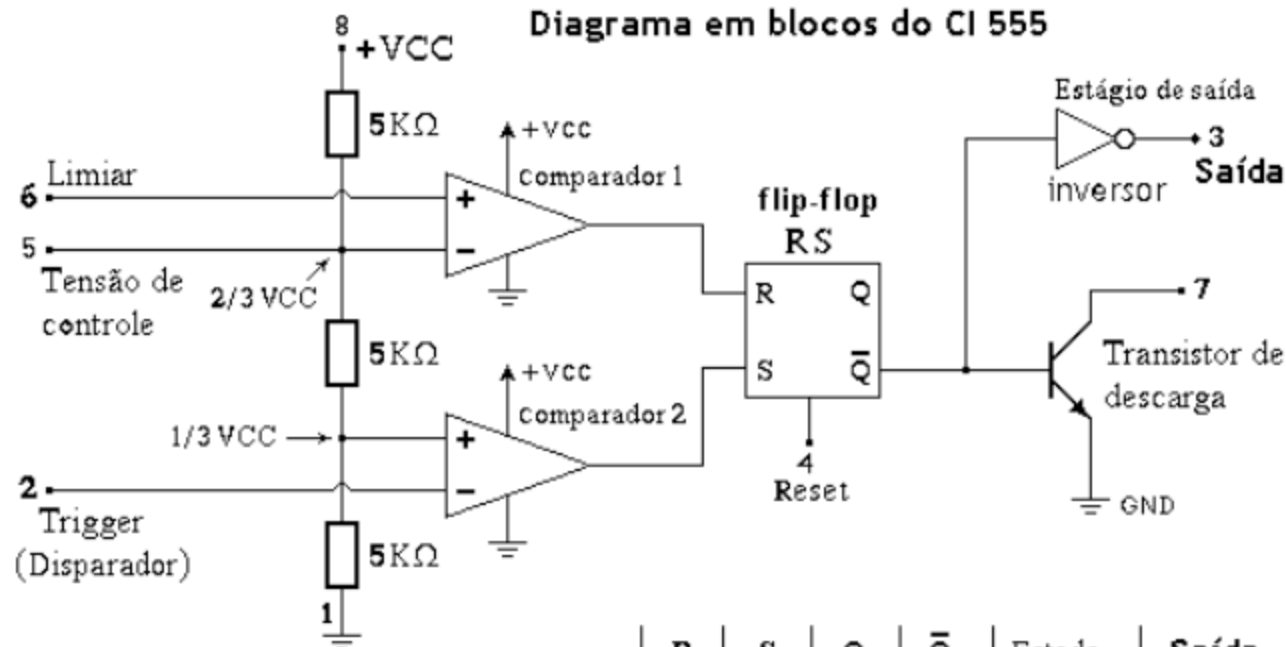

$V_6 < 2/3 V_{CC} \Rightarrow R = 0$
 $V_2 < 1/3 V_{CC} \Rightarrow S = 1$

 $V_6 > 2/3 V_{CC} \Rightarrow R = 1$
 $V_2 > 1/3 V_{CC} \Rightarrow S = 0$

 $V_6 \Rightarrow$ tensão no pino 6
 $V_2 \Rightarrow$ tensão no pino 2

R	S	Q	\bar{Q}	Estado	Saída
0	0	Não muda		Hold	não muda
0	1	1	0	Set	1
1	0	0	1	Reset	0
1	1	0	0	Proibido	1

flip-flop

The 555 timer consists of two voltage comparators (op amplifiers), a bistable flip-flop, a discharge transistor, and a resistor divider network. See the block form in Figure. A Monostable circuit.

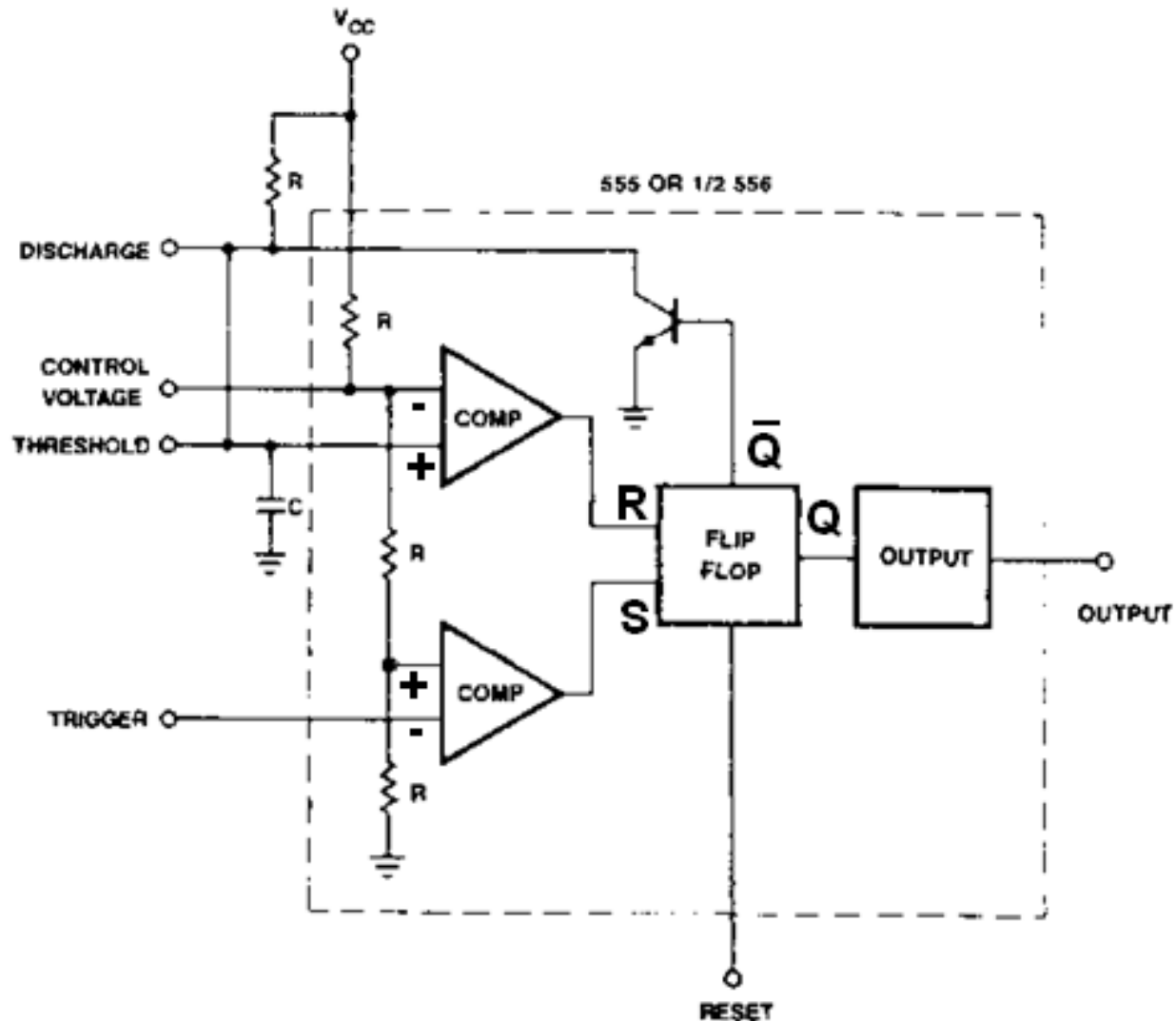

Negative edge triggered Mono-stable circuit. 555

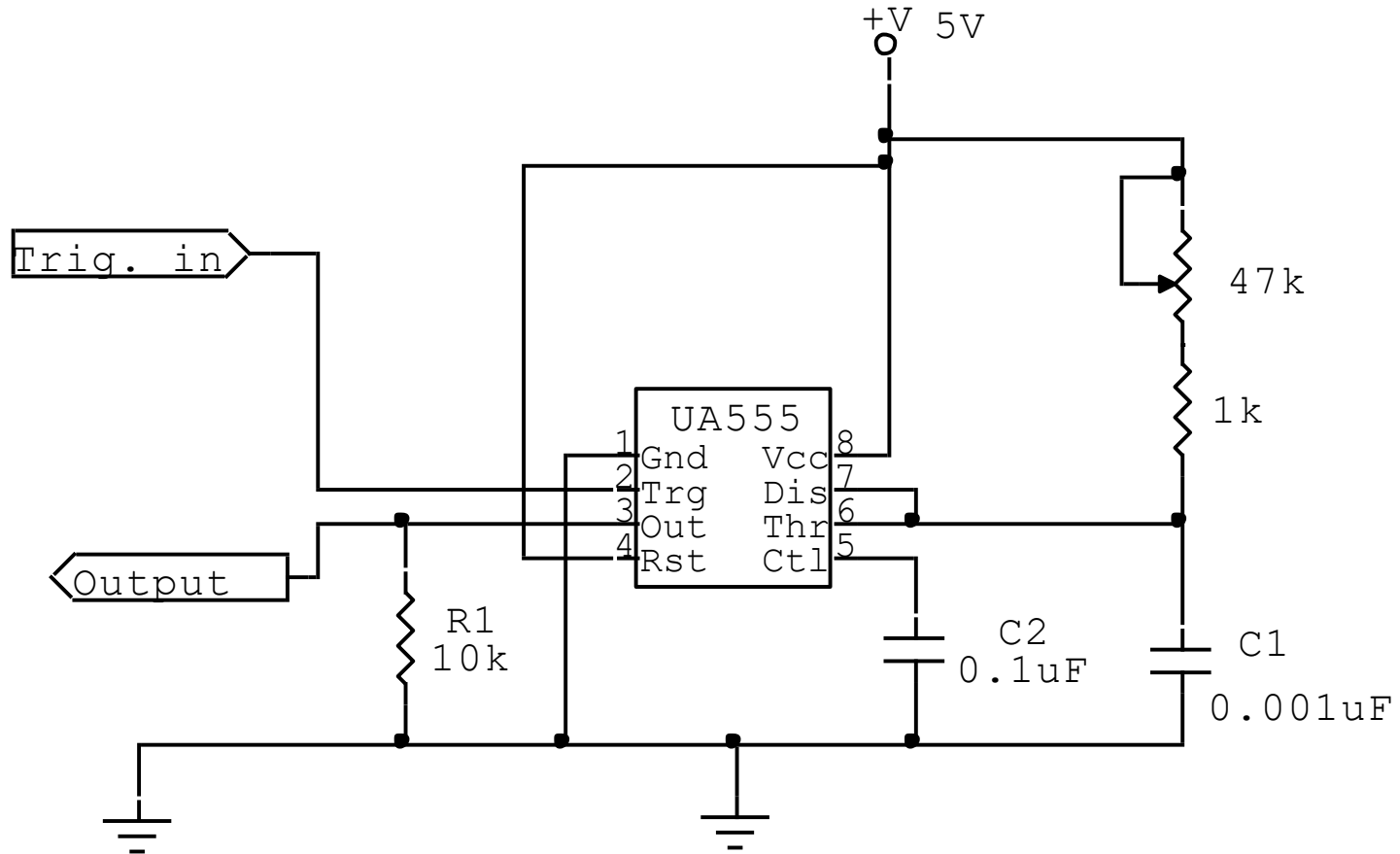

By AC coupling the trigger , a short negative-going pulse is achieved when the trigger signal goes to ground.

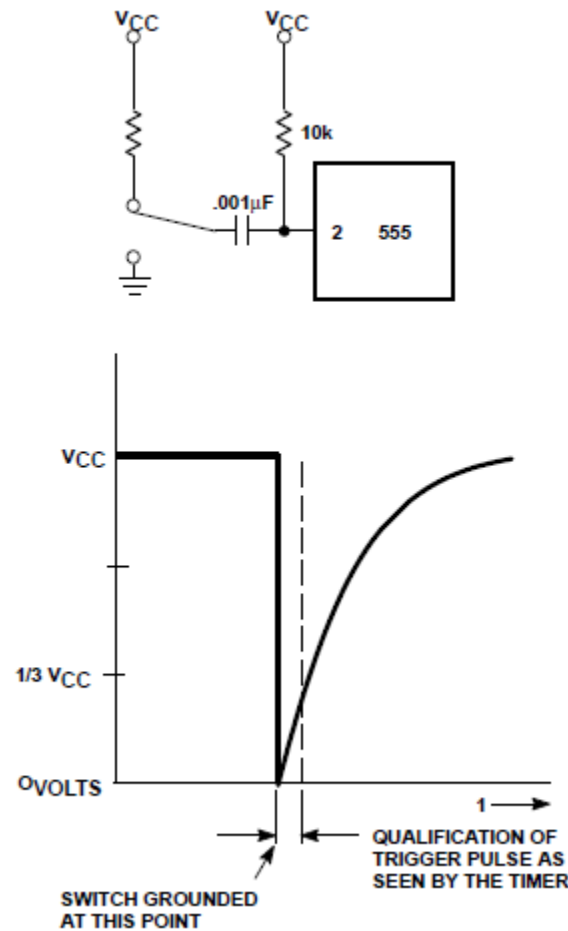

Upon application of the negative pulse to pin 2, the FF is Set which releases the short circuit across the external capacitor C and drives the output High. The capacitor charges in a time $1.1R_A C$. When the voltage across the capacitor reaches $2/3 V_{CC}$, the comparator resets the FF discharging C and output goes Low.

Astable operation- 555

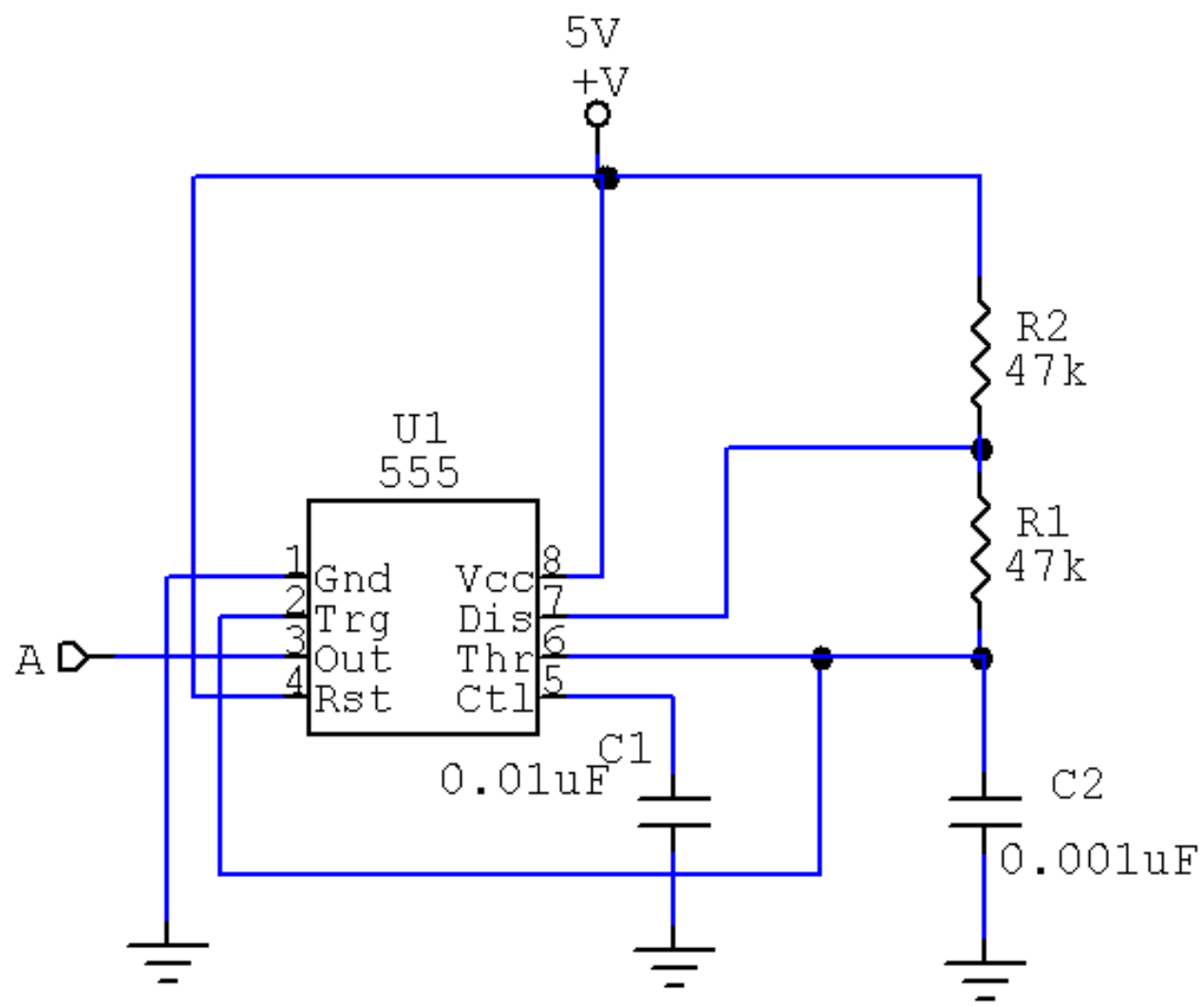

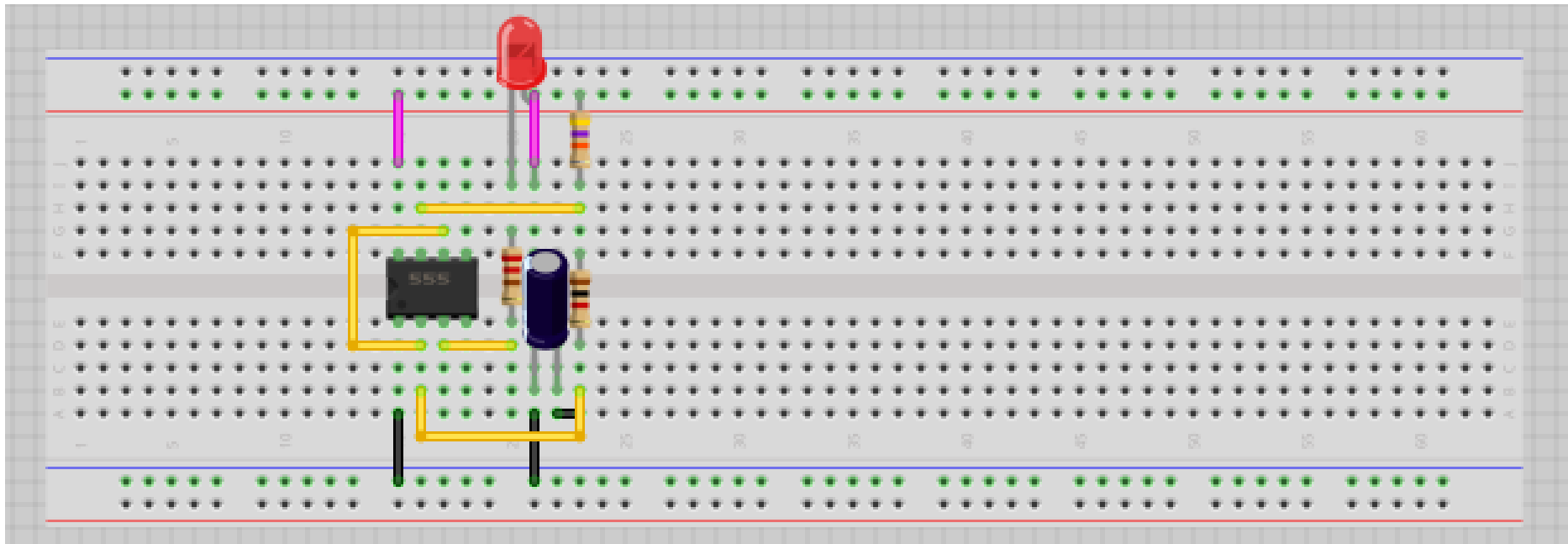

PWM

- In this configuration, the monostable circuit is triggered by the astable circuit.
- By changing the variable resistor $R=47k$ we change the pulse width.
- By applying a 2V sinusoidal modulating voltage to pin 5 of the mono, we modulate the pulse width.

This PWM is used in Class d amplifier.

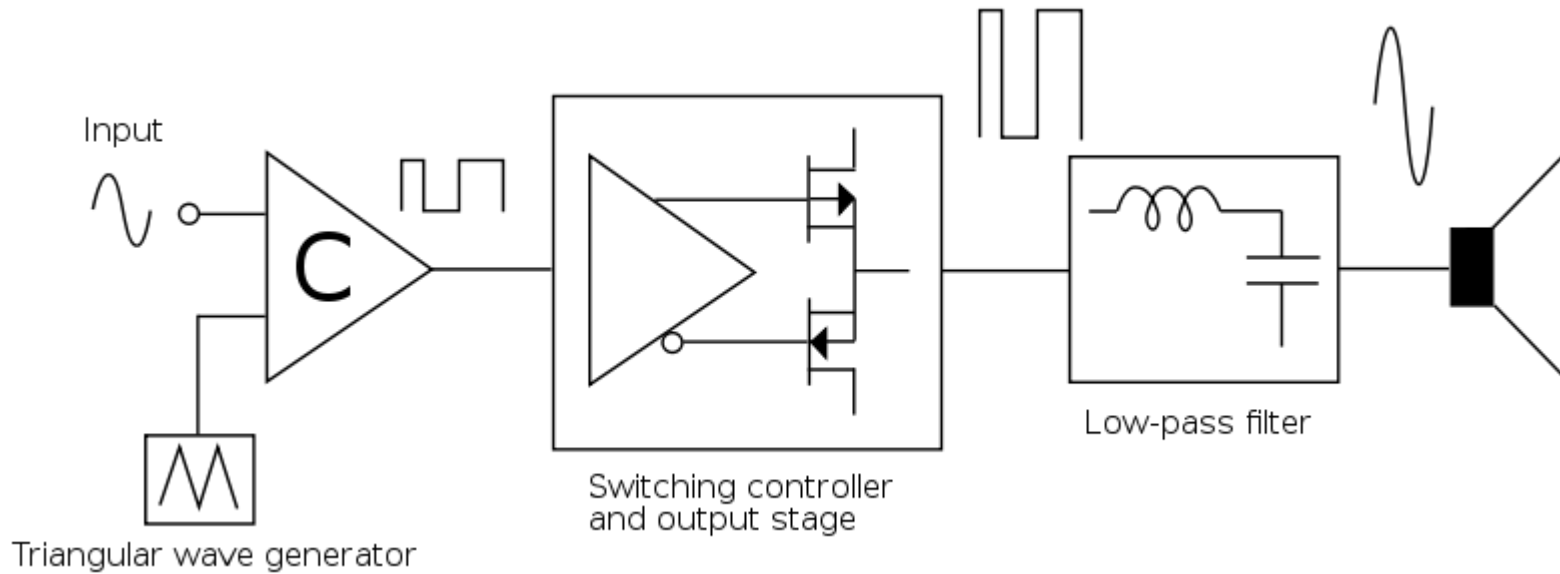

Fim